

WESTGATE BUSINESS PARK PLAT 5

FINAL PLAT

INDEX LEGEND
 LOCATION: LOTS 1 & 2, WESTGATE BUSINESS PARK PLAT 2, WAUKEE
 REQUESTOR: ACCESS SYSTEMS
 PROPRIETOR: JACE PROPERTIES LLC
 SURVEYOR: MICHAEL A. BROONER
 COMPANY: CIVIL DESIGN ADVANTAGE
 RETURN TO: CIVIL DESIGN ADVANTAGE
 4121 NW URBANDALE DRIVE
 URBANDALE, IOWA 50322
 PH: 515-369-4400

REVISIONS	DATE
	01/18/22

4121 NW URBANDALE DRIVE
 URBANDALE, IOWA 50322
 PHONE: (515) 369-4400 FAX: (515) 369-4410
 TECH: _____
 ENGINEER: _____

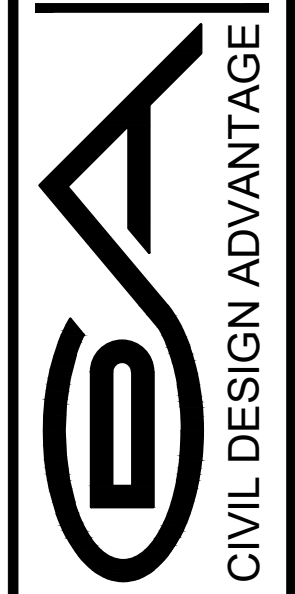

WESTGATE BUSINESS PARK PLAT 5
FINAL PLAT
 WAUKEE, IOWA

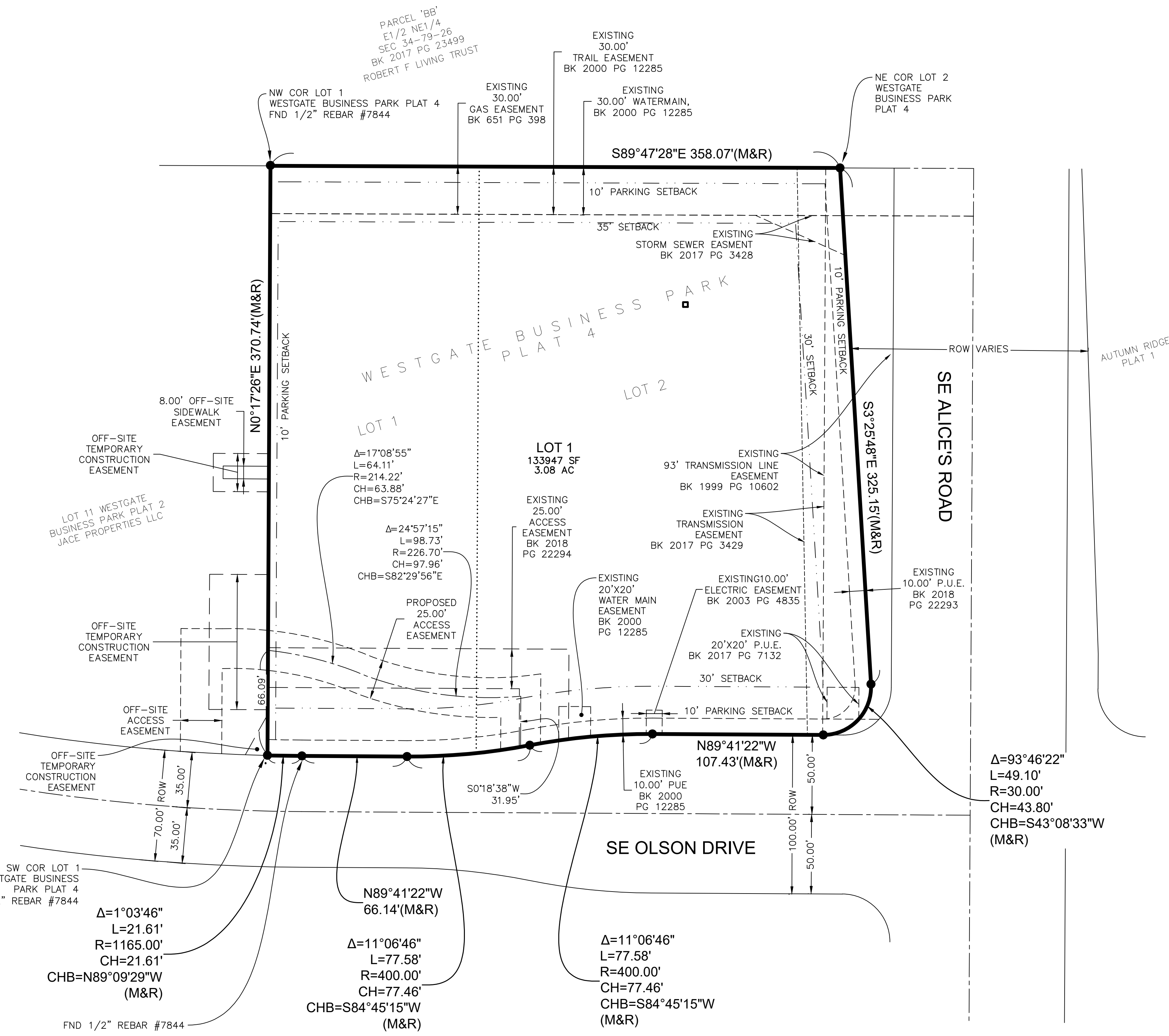

VICINITY MAP WAUKEE, IA

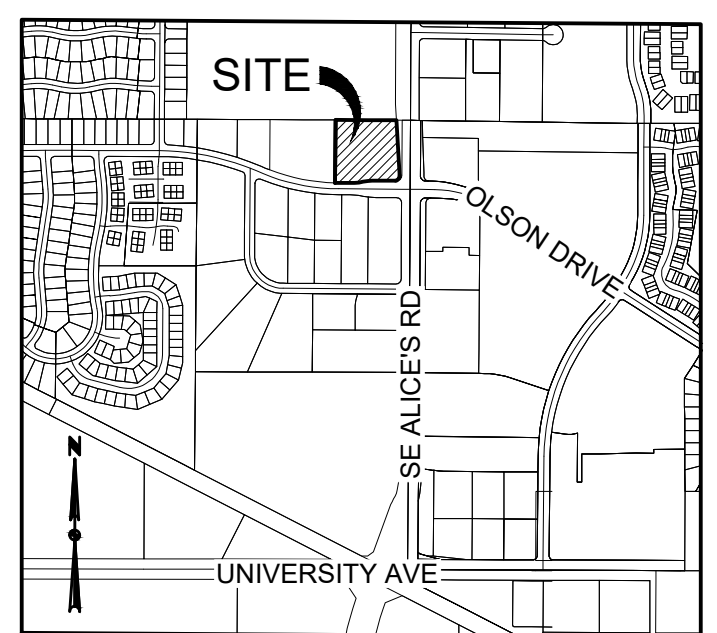

LEGEND

	FOUND	SET
SECTION CORNER AS NOTED	▲	△
1/2" REBAR, YELLOW CAP #15980 (UNLESS OTHERWISE NOTED)	●	○
MEASURED BEARING & DISTANCE	M	
RECORDED BEARING & DISTANCE	R	
DEEDED BEARING & DISTANCE	D	
PUBLIC UTILITY EASEMENT	P.U.E.	
CURVE ARC LENGTH	AL	
LOT ADDRESS	(1234)	
CENTERLINE	---	
SECTION LINE	---	
EASEMENT LINE	---	
BUILDING SETBACK LINE	---	
PLAT BOUNDARY	---	

OWNER / DEVELOPER
 JACE PROPERTIES
 975 SE OLSON DRIVE
 WAUKEE, IA 50283
 CONTACT: JANETTE MARTENS
 PH: (515) 987-6227

ENGINEER / SURVEYOR
 CIVIL DESIGN ADVANTAGE
 4121 NW URBANDALE DRIVE
 URBANDALE, IOWA 50322

ZONING
 M-1/PD-1 PLANNED DEVELOPMENT DISTRICT W/
 UNDERLYING M-1 - LIGHT INDUSTRIAL
 (ORDINANCE # 2397)

BULK REGULATIONS
SETBACKS
 FRONT YARD= 30 FEET
 SIDE YARD= NONE
 REAR YARD= 35 FEET

DATE OF SURVEY
 DECEMBER 15, 2021

PLAT DESCRIPTION
 LOTS 1 & 2, WESTGATE BUSINESS PARK PLAT 4, AN
 OFFICIAL PLAT IN THE CITY OF WAUKEE, DALLAS COUNTY,
 IOWA. PROPERTY CONTAINS 3.08 ACRES (133,947 S.F.)
 AND IS SUBJECT TO ANY AND ALL EASEMENTS OF
 RECORD.

NOTES
 1. ANY SET MONUMENTATION SHOWN ON THIS PLAT WILL
 BE COMPLETED WITHIN ONE YEAR FROM THE DATE
 THIS PLAT WAS RECORDED.

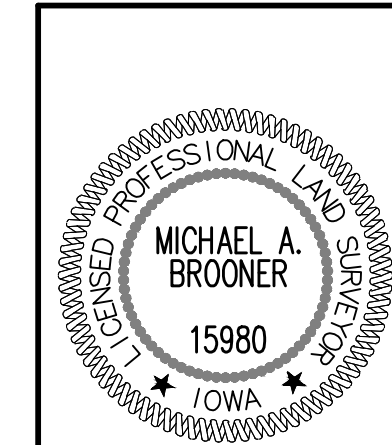

I HEREBY CERTIFY THAT THIS LAND SURVEYING DOCUMENT WAS
 PREPARED AND THE RELATED SURVEY WORK WAS PERFORMED
 BY ME OR UNDER MY DIRECT PERSONAL SUPERVISION AND
 THAT I AM A DULY LICENSED PROFESSIONAL LAND SURVEYOR
 UNDER THE LAWS OF THE STATE OF IOWA.

MICHAEL A. BROONER, P.L.S. DATE _____

MY LICENSE RENEWAL DATE IS DECEMBER 31, 2022
 PAGES OR SHEETS COVERED BY THIS SEAL:
 THIS SHEET _____

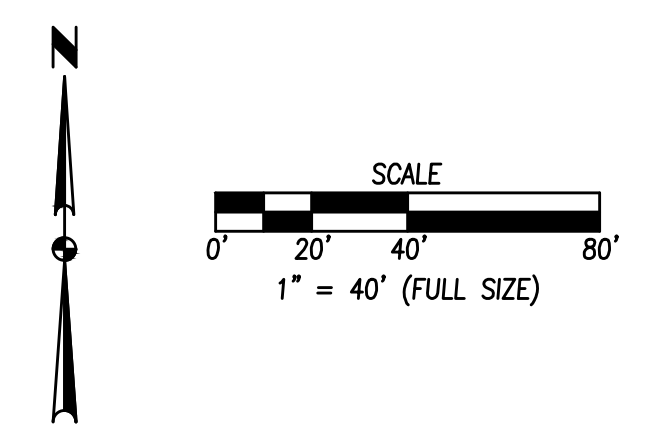

FILE: H:\2021\2111901\DWG\2111901-FINAL PLAT.DWG
 DATE: 1/18/22 DATE PLOTTED: 2/15/2022 11:49 AM