

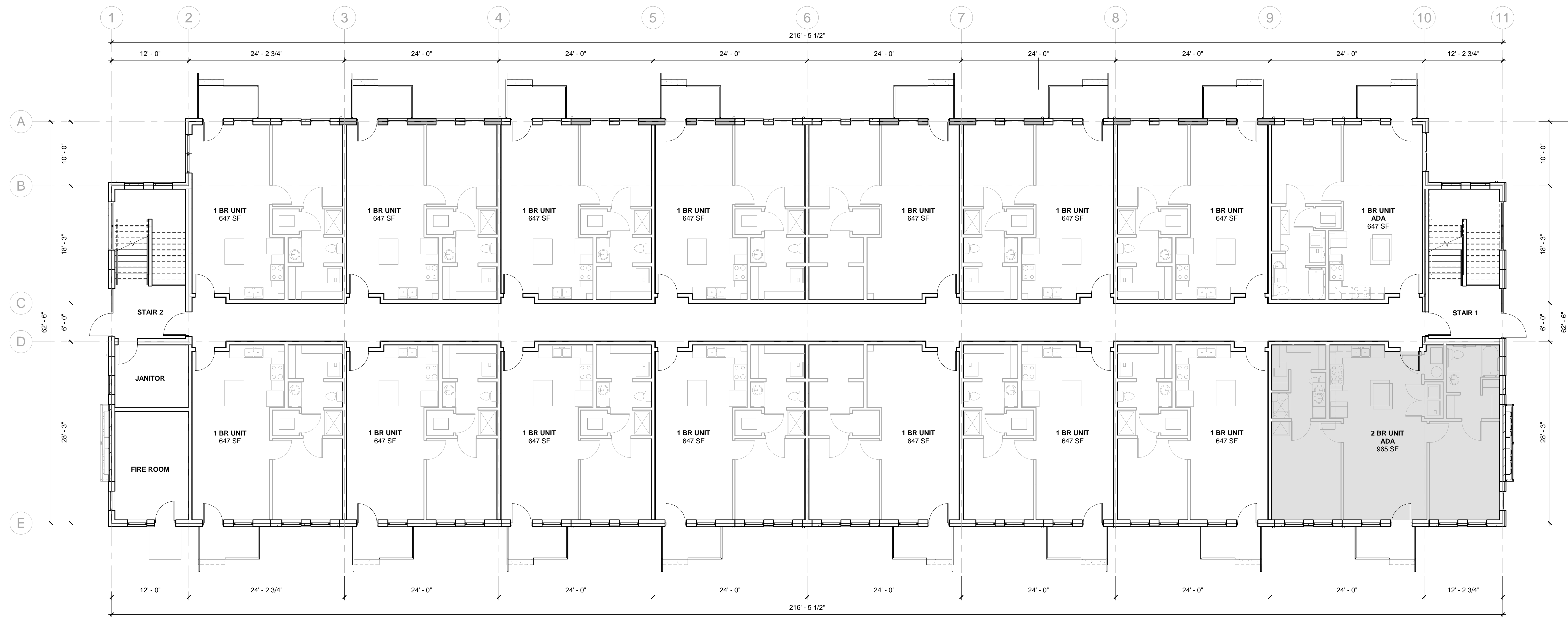

02 48 PLEX - SECOND FLOOR PLAN
1/8" = 1'-0"

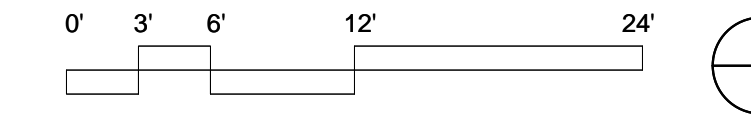

01 48 PLEX - FIRST FLOOR PLAN
1/8" = 1'-0"

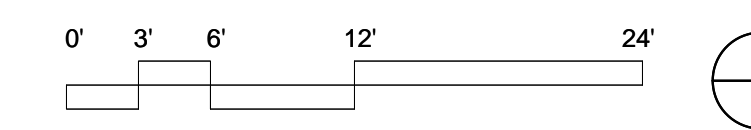

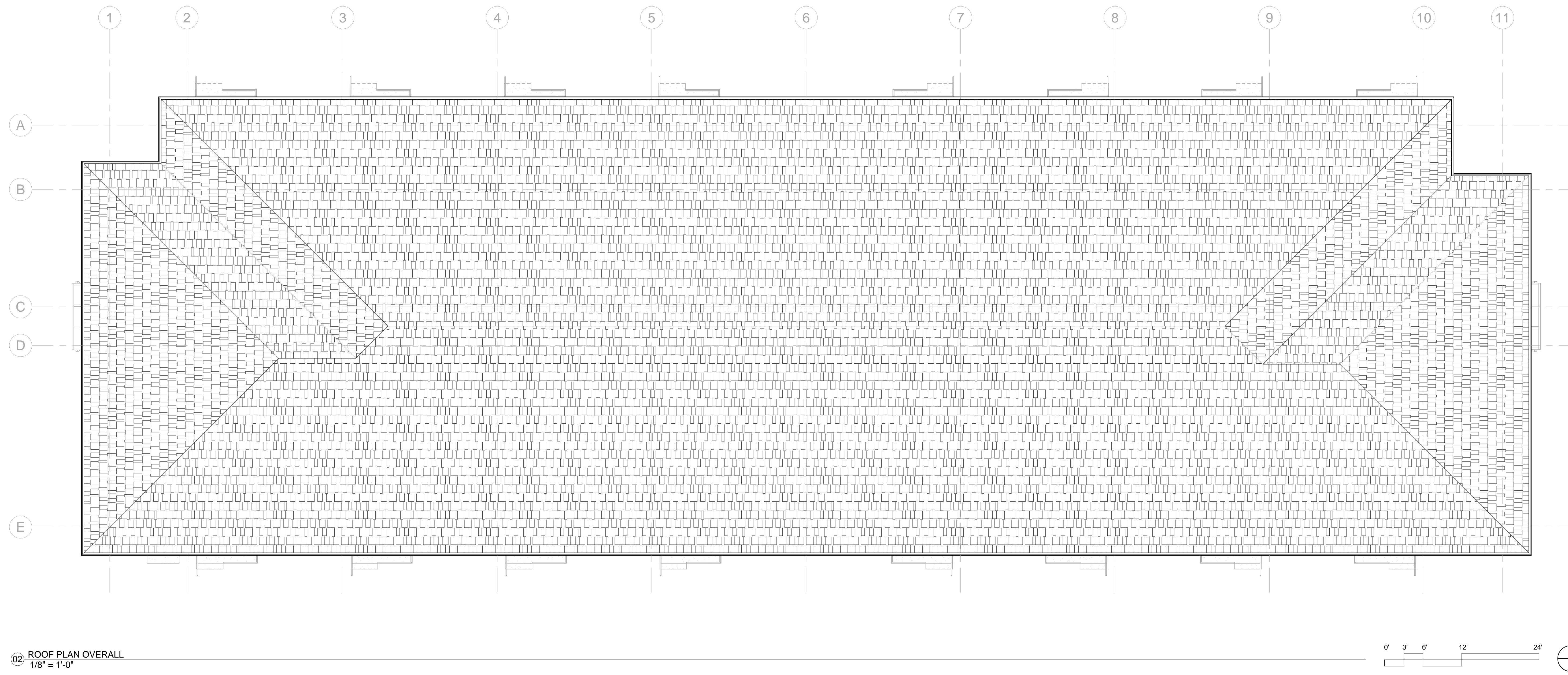



BRICK 1 - "WILLIAMSBURG - GRAYHAWK" - 1,358 SF (15.43%)
 BRICK 2 - "WILLIAMSBURG - SMOKEY MOUNTAIN" - 1,772 SF (20.13%)
 BRICK 3 - "WILLIAMSBURG - STONE CITY" - 3,058 SF (34.74%)
 WINDOWS/DOORS (GLASS) - 2,614 SF (29.7%)

04. 66 PLEX - WEST ELEVATION
 1/8" = 1'-0"



BRICK 1 - "WILLIAMSBURG - GRAYHAWK" - 660 SF (34.20%)
 BRICK 2 - "WILLIAMSBURG - STONE CITY" - 0 SF (0.00%)
 BRICK 3 - "WILLIAMSBURG - SMOKEY MOUNTAIN" - 676 SF (35.02%)
 WINDOWS/DOORS (GLASS) - 594 SF (30.78%)

03. 66 PLEX - SOUTH ELEVATION
 1/8" = 1'-0"



BRICK 1 - "WILLIAMSBURG - GRAYHAWK" - 660 SF (34.20%)
 BRICK 2 - "WILLIAMSBURG - STONE CITY" - 0 SF (0.00%)
 BRICK 3 - "WILLIAMSBURG - SMOKEY MOUNTAIN" - 676 SF (35.02%)
 WINDOWS/DOORS (GLASS) - 594 SF (30.78%)

02. 66 PLEX - NORTH ELEVATION
 1/8" = 1'-0"



BRICK 1 - "WILLIAMSBURG - GRAYHAWK" - 1,205 SF (13.70%)
 BRICK 2 - "WILLIAMSBURG - SMOKEY MOUNTAIN" - 1,700 SF (19.31%)
 BRICK 3 - "WILLIAMSBURG - STONE CITY" - 3,058 SF (34.74%)
 WINDOWS/DOORS (GLASS) - 2,839 SF (32.25%)

01. 66 PLEX - EAST ELEVATION
 1/8" = 1'-0"



02 66 PLEX - SECOND FLOOR PLAN
1/8" = 1'-0"



01 66 PLEX - FIRST FLOOR PLAN
1/8" = 1'-0"

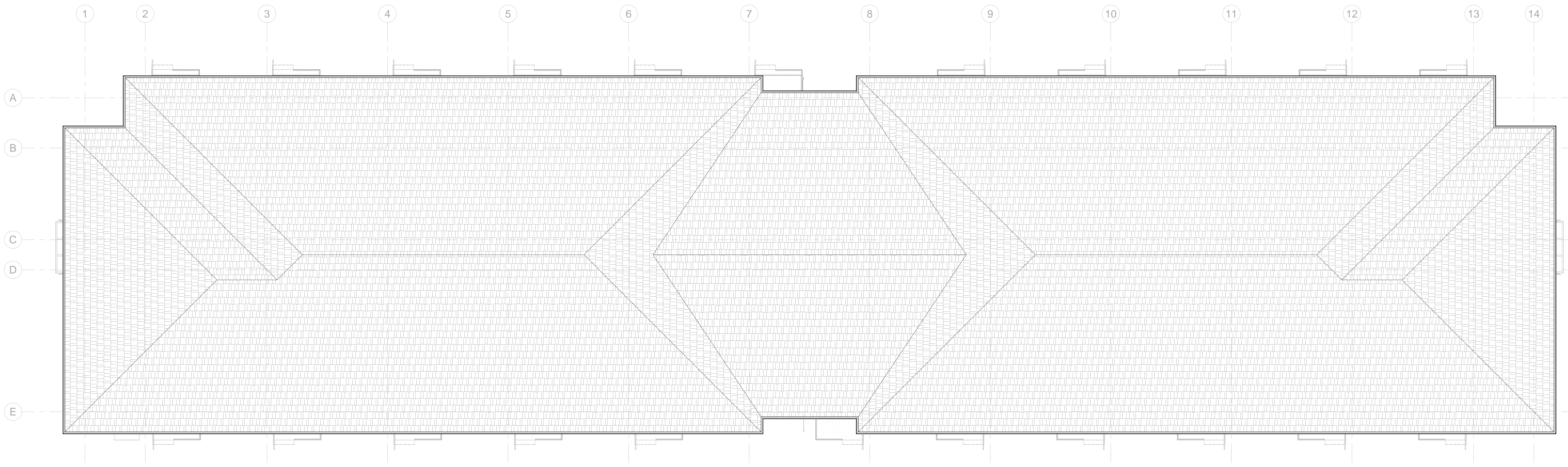

02 ROOF PLAN OVERALL
1/8" = 1'-0"

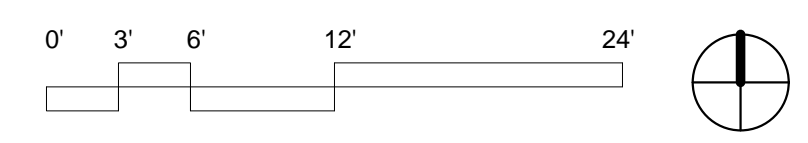

01 66 PLEX - THIRD FLOOR PLAN
1/8" = 1'-0"

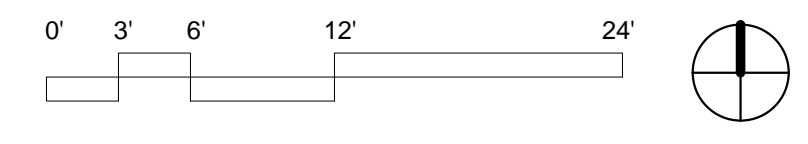





02 66 PLEX - SECOND FLOOR PLAN
1/8" = 1'-0"



01 66 PLEX - FIRST FLOOR PLAN
1/8" = 1'-0"

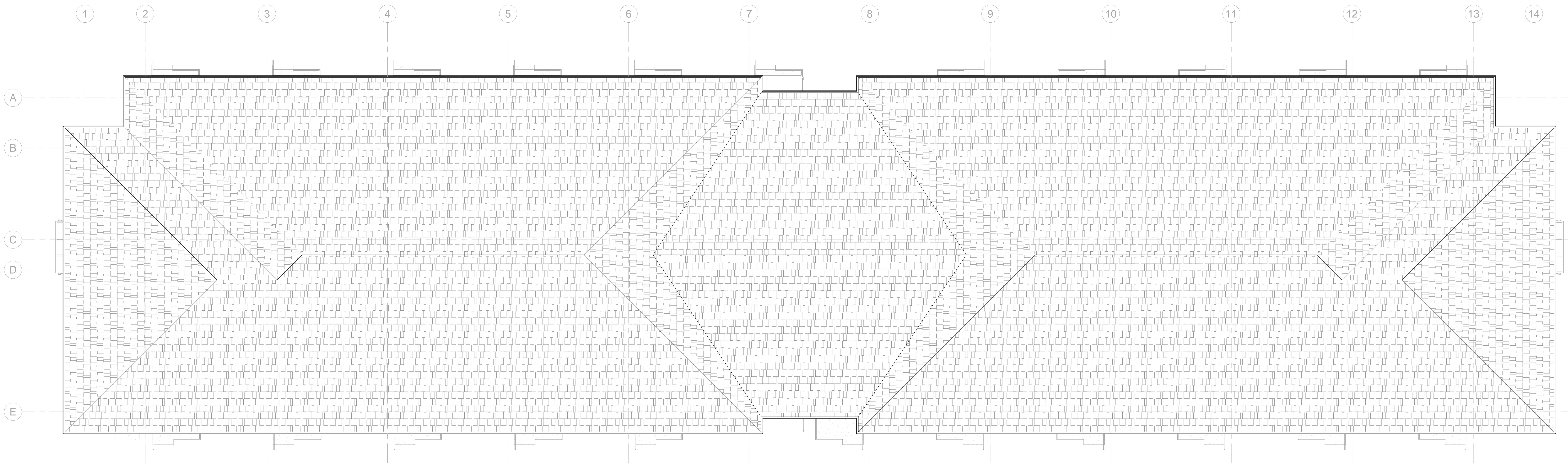

02 ROOF PLAN OVERALL
1/8" = 1'-0"

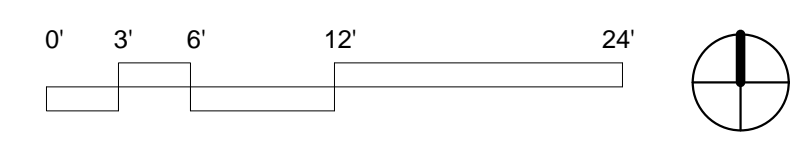

01 66 PLEX - THIRD FLOOR PLAN
1/8" = 1'-0"

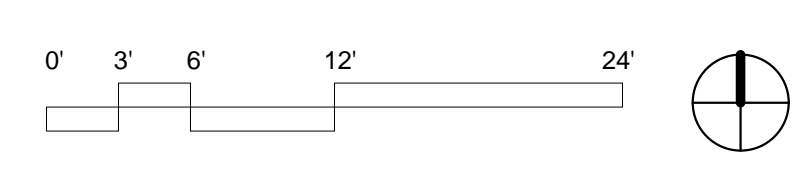



17 EAST ELEVATION - RENDERED
1/8" = 1'-0"

BRICK 1 - "WILLIAMSBURG - STONE CITY" - 392 SF (29.74%)
BRICK 2 - "WILLIAMSBURG - GRAYHAWK" - 502 SF (38.09%)
BRICK 3 - "WILLIAMSBURG - SMOKEY MOUNTAIN" - 0 SF (0%)
WINDOW/DOORS (GLASS) - 424 SF (31.36%)



16 NORTH ELEVATION - RENDERED
1/8" = 1'-0"

BRICK 1 - "WILLIAMSBURG - STONE CITY" - 190 SF (24.17%)
BRICK 2 - "WILLIAMSBURG - GRAYHAWK" - 510 SF (64.89%)
BRICK 3 - "WILLIAMSBURG - SMOKEY MOUNTAIN" - 0 SF (0%)
WINDOW/DOORS (GLASS) - 86 SF (10.94%)



15 WEST ELEVATION - RENDERED
1/8" = 1'-0"

BRICK 1 - "WILLIAMSBURG - STONE CITY" - 372 SF (28.22%)
BRICK 2 - "WILLIAMSBURG - GRAYHAWK" - 500 SF (37.94%)
BRICK 3 - "WILLIAMSBURG - SMOKEY MOUNTAIN" - 0 SF (0%)
WINDOW/DOORS (GLASS) - 446 SF (33.84%)



14 SOUTH ELEVATION - RENDERED
1/8" = 1'-0"

BRICK 1 - "WILLIAMSBURG - STONE CITY" - 218 SF (27.74%)
BRICK 2 - "WILLIAMSBURG - GRAYHAWK" - 356 SF (45.29%)
BRICK 3 - "WILLIAMSBURG - SMOKEY MOUNTAIN" - 0 SF (0%)
WINDOW/DOORS (GLASS) - 212 SF (26.97%)

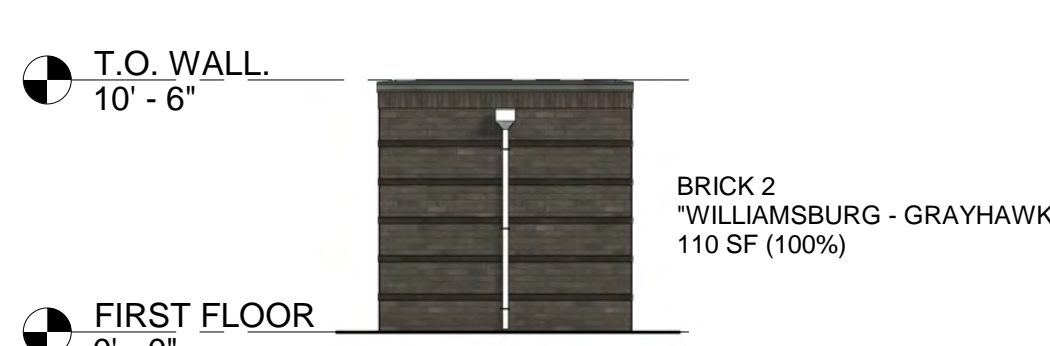

12 POOL EQUIP. ELEVATION B.
1/8" = 1'-0"



11 POOL EQUIP. ELEVATION C.
1/8" = 1'-0"



10 POOL EQUIP. ELEVATION A.
1/8" = 1'-0"

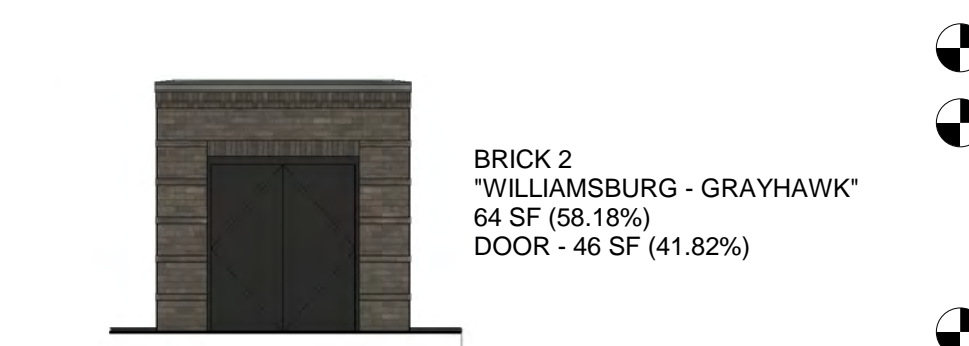

09 POOL EQUIP. ELEVATION D.
1/8" = 1'-0"



08 POOL RR ELEVATION D.
1/8" = 1'-0"



07 POOL RR ELEVATION C.
1/8" = 1'-0"

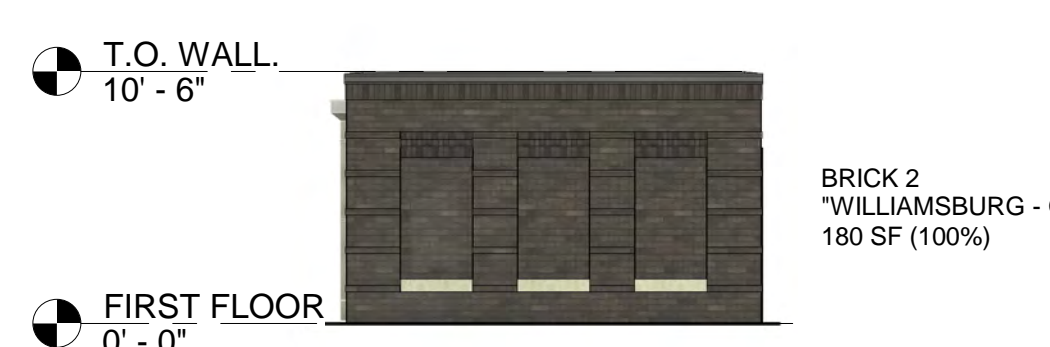

06 POOL STORAGE ELEVATION A.
1/8" = 1'-0"



05 POOL STORAGE ELEVATION B.
1/8" = 1'-0"



04 POOL STORAGE ELEVATION D.
1/8" = 1'-0"

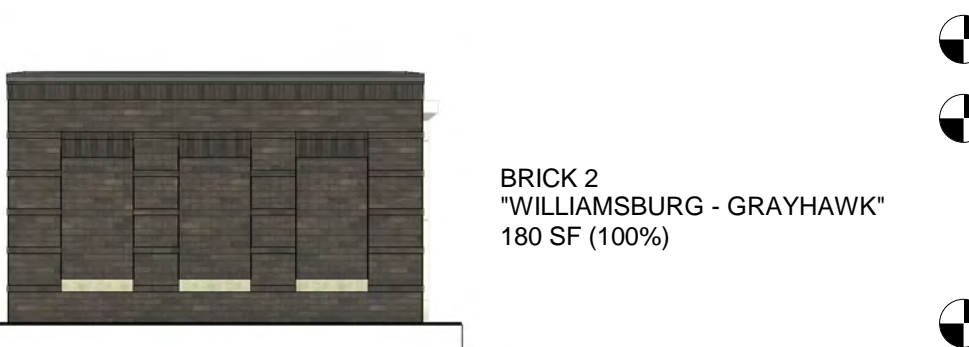

03 POOL STORAGE ELEVATION C.
1/8" = 1'-0"

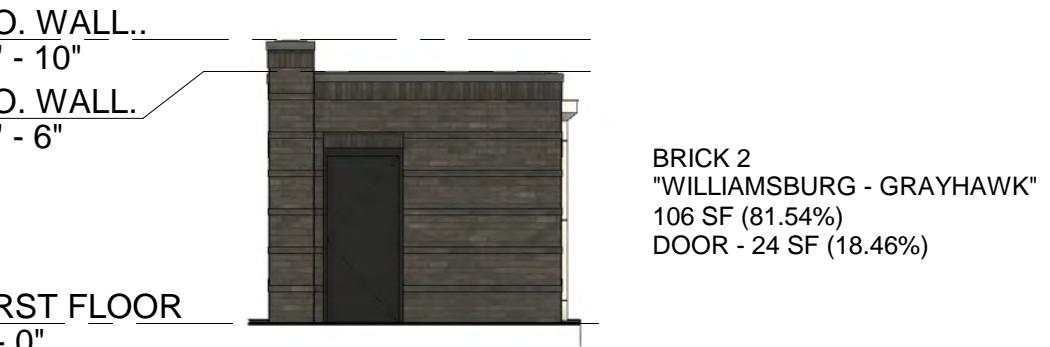

02 POOL RR ELEVATION A.
1/8" = 1'-0"

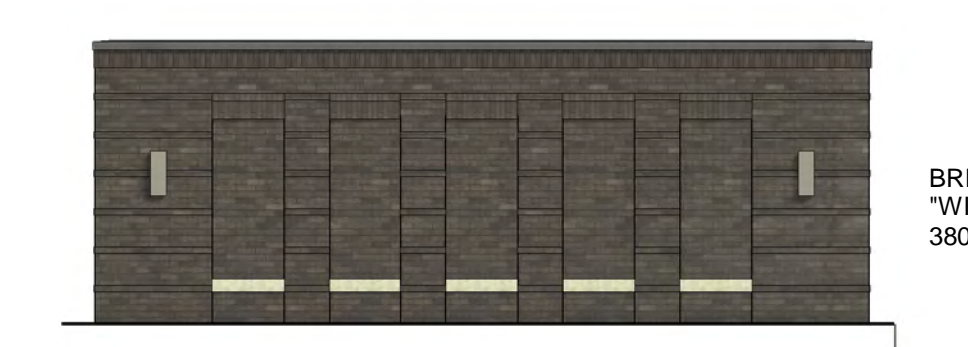

01 POOL RR ELEVATION B.
1/8" = 1'-0"

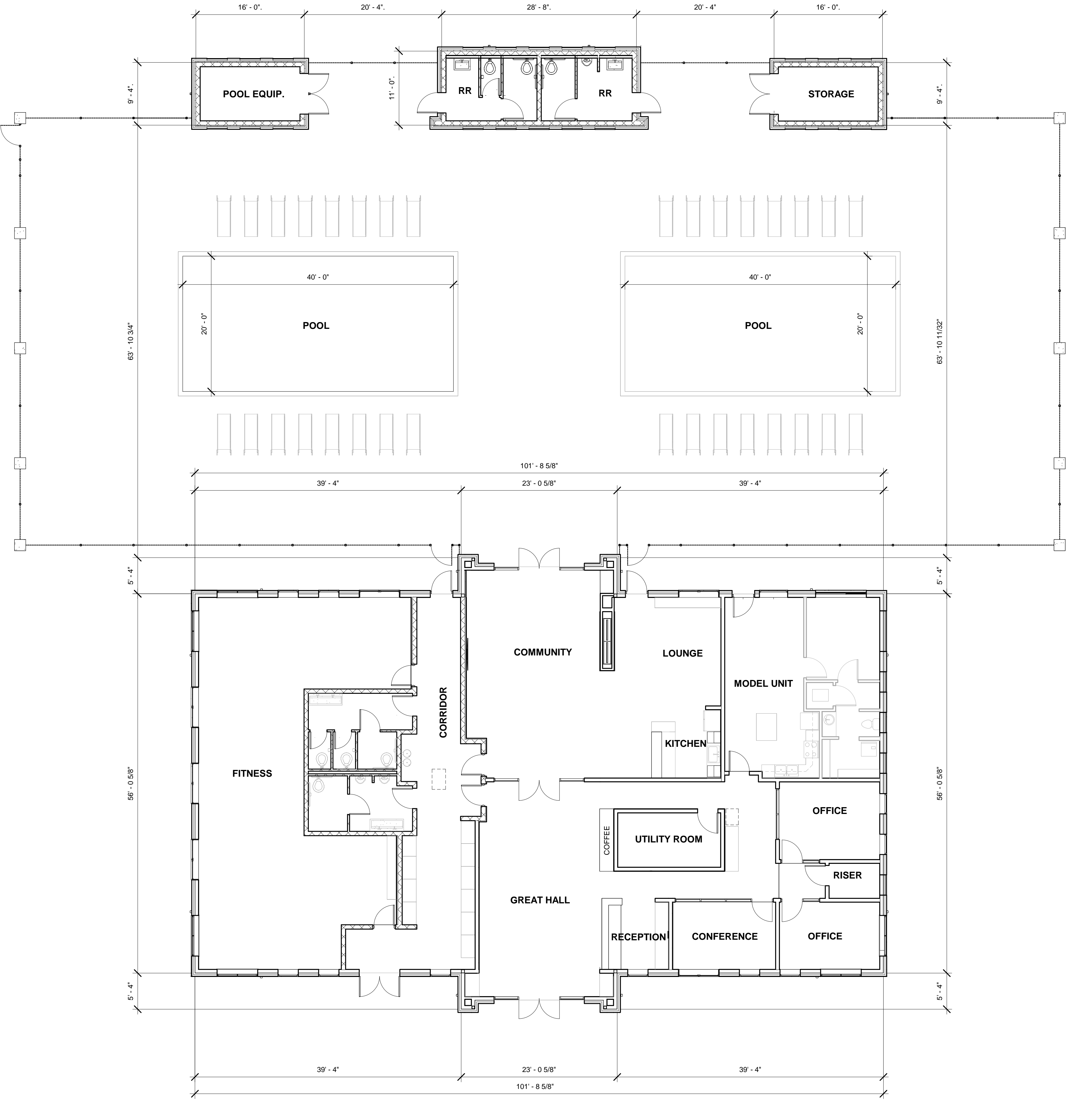

13 CLUBHOUSE FLOOR PLAN
1/8" = 1'-0"

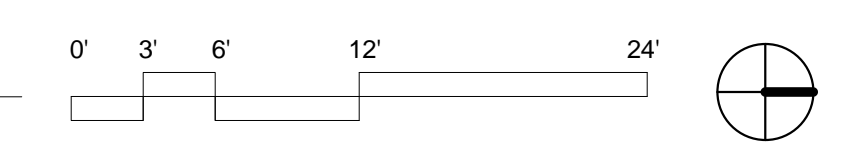

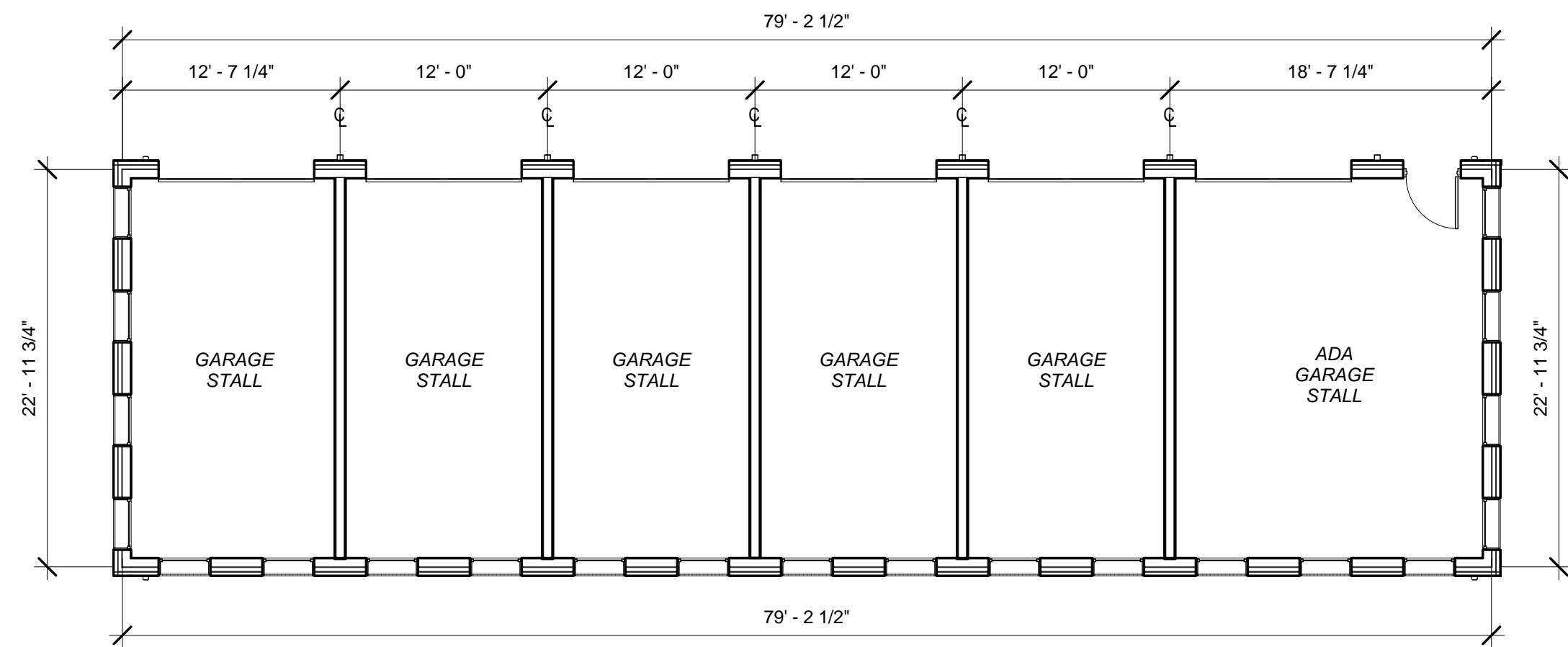

15 ADA GARAGE FLOOR PLAN
1/8" = 1'-0"

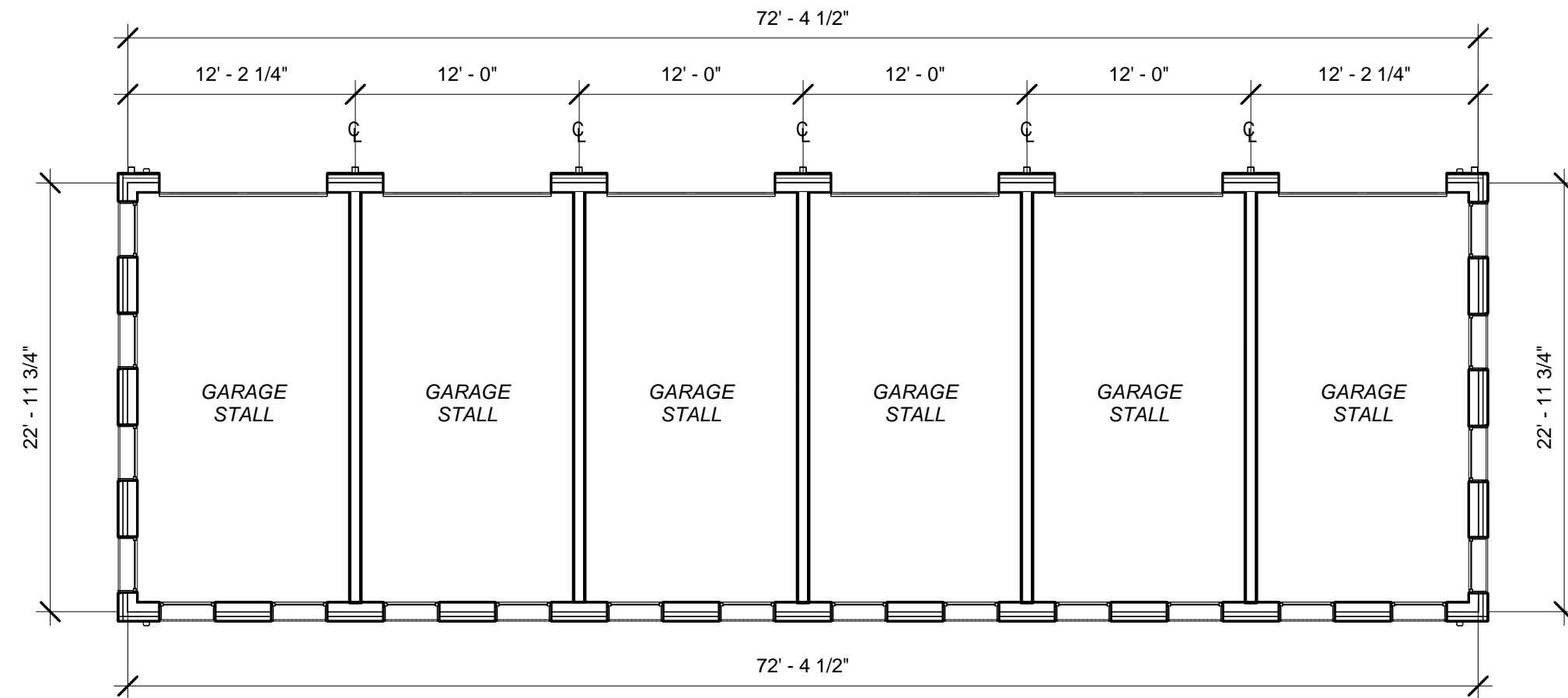

14 STANDARD GARAGE FLOOR PLAN
1/8" = 1'-0"

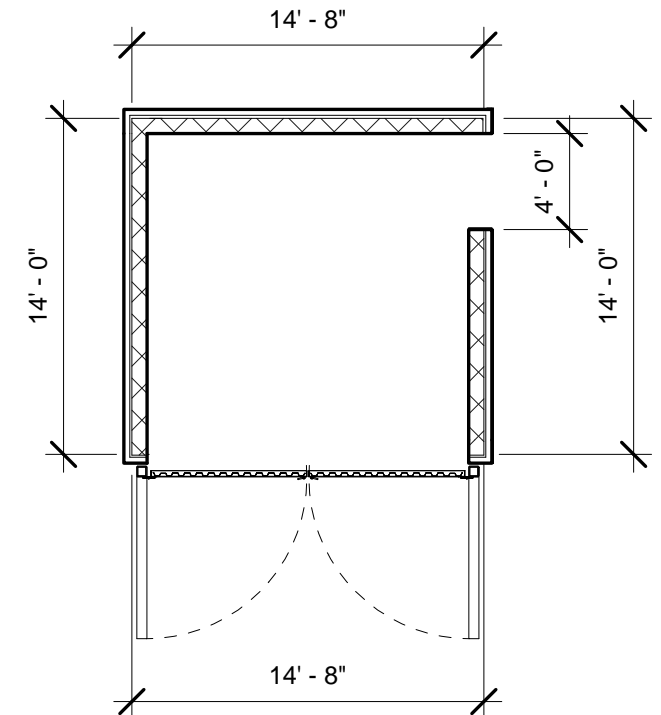

13 TRASH ENCLOSURE FLOOR PLAN
1/8" = 1'-0"



12 ADA GARAGE B
1/8" = 1'-0"



11 STANDARD GARAGE B
1/8" = 1'-0"



10 TRASH ENCLOSURE A
1/8" = 1'-0"

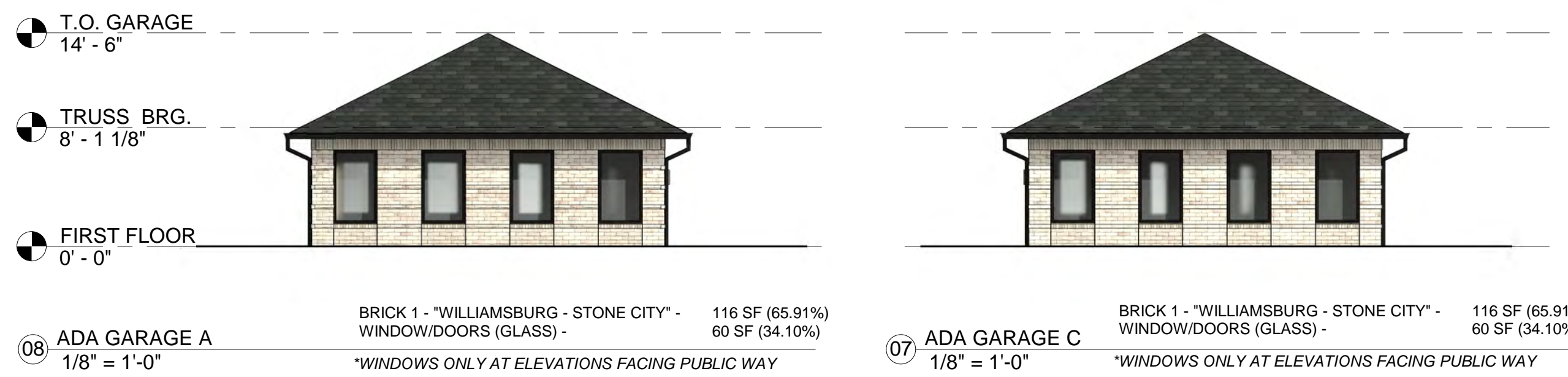

08 ADA GARAGE A
1/8" = 1'-0"

07 ADA GARAGE C
1/8" = 1'-0"

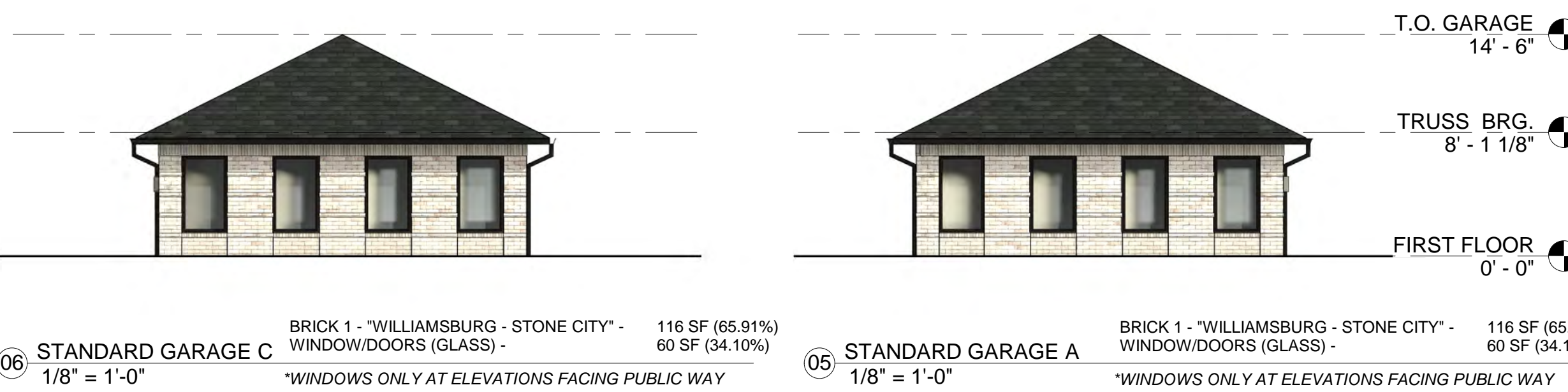

06 STANDARD GARAGE C
1/8" = 1'-0"

05 STANDARD GARAGE A
1/8" = 1'-0"



09 TRASH ENCLOSURE B
1/8" = 1'-0"



03 ADA GARAGE D
1/8" = 1'-0"



02 STANDARD GARAGE D
1/8" = 1'-0"

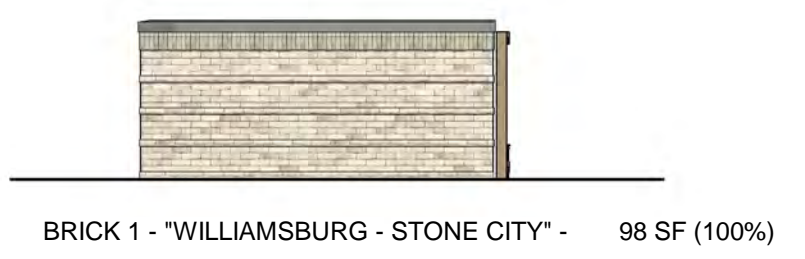

04 TRASH ENCLOSURE C
1/8" = 1'-0"



01 TRASH ENCLOSURE D
1/8" = 1'-0"

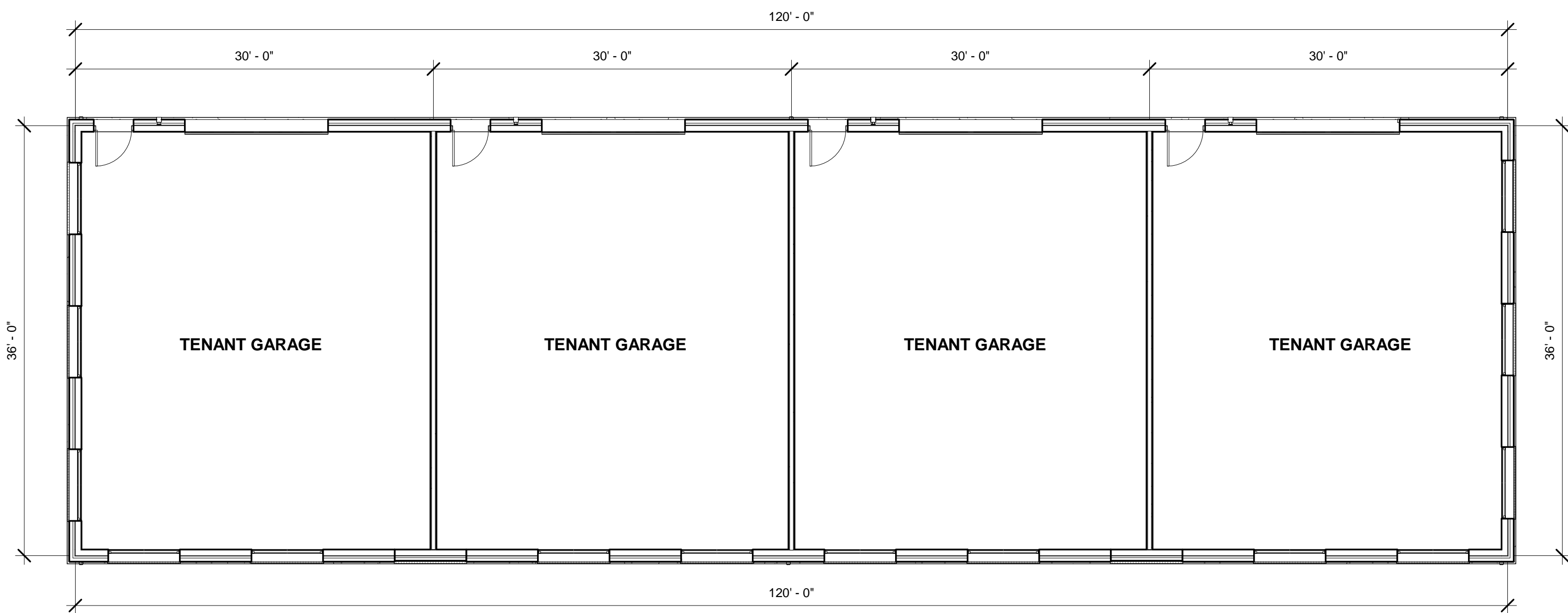

10 GARAGE A PLAN
1/8" = 1'-0"

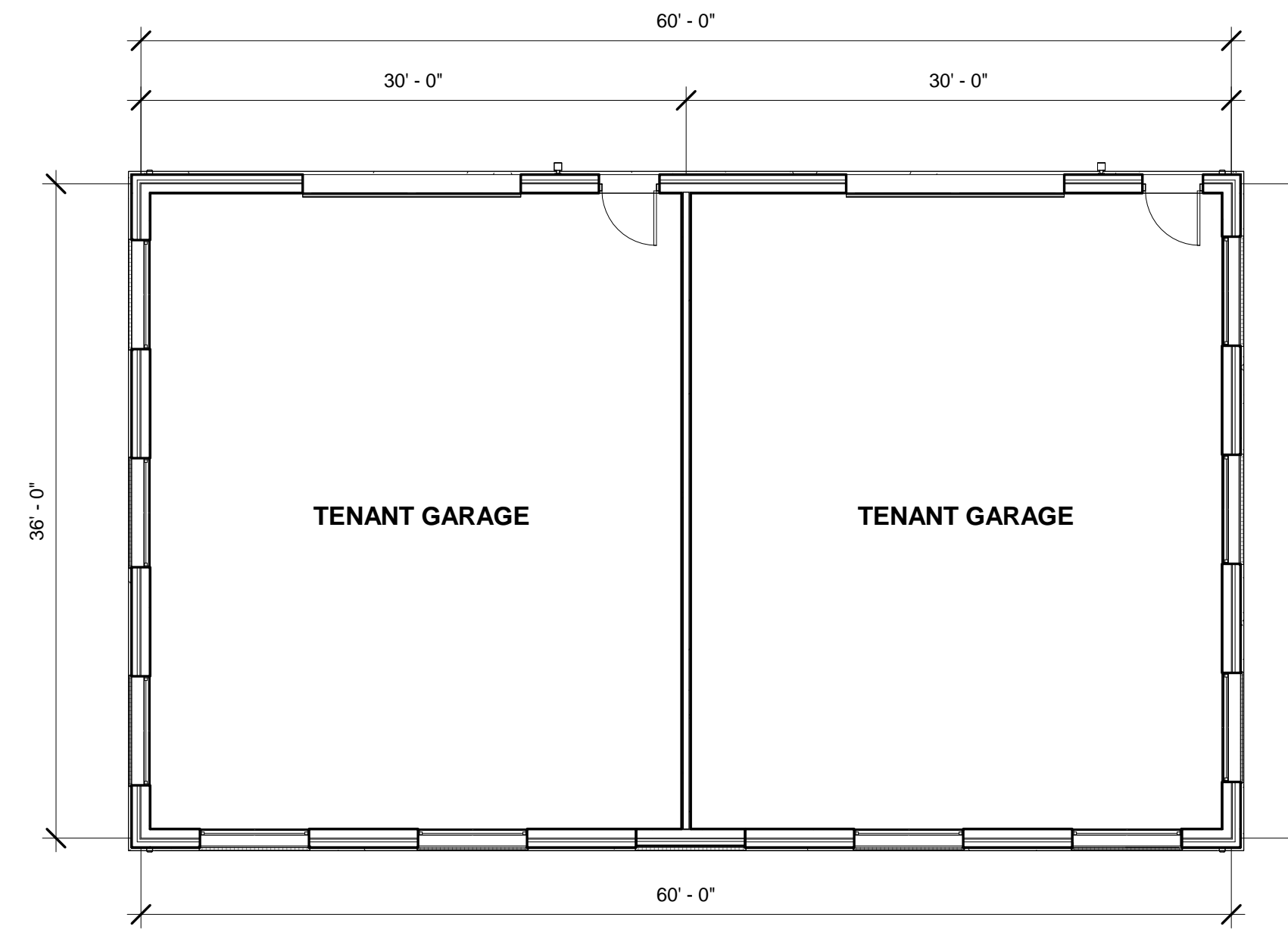

09 GARAGE B PLAN
1/8" = 1'-0"



08 GARAGE A ELEVATION EAST
1/8" = 1'-0"

BRICK 1 - "WILLIAMSBURG - STONE CITY" - 898 SF (61.84%)
WINDOW/DOORS (GLASS) - 554 SF (38.16%)



07 GARAGE B ELEVATION EAST
1/8" = 1'-0"

BRICK 1 - "WILLIAMSBURG - STONE CITY" - 508 SF (69.40%)
WINDOW/DOORS (GLASS) - 224 SF (30.60%)



06 GARAGE A ELEVATION NORTH
1/8" = 1'-0"

BRICK 1 - "WILLIAMSBURG - STONE CITY" - 304 SF (67.86%)
WINDOW/DOORS (GLASS) - 144 SF (32.14%)



05 GARAGE A ELEVATION SOUTH
1/8" = 1'-0"

BRICK 1 - "WILLIAMSBURG - STONE CITY" - 304 SF (67.86%)
WINDOW/DOORS (GLASS) - 144 SF (32.14%)



04 GARAGE B ELEVATION NORTH
1/8" = 1'-0"

BRICK 1 - "WILLIAMSBURG - STONE CITY" - 304 SF (67.86%)
WINDOW/DOORS (GLASS) - 144 SF (32.14%)



03 GARAGE B ELEVATION SOUTH
1/8" = 1'-0"

BRICK 1 - "WILLIAMSBURG - STONE CITY" - 304 SF (67.86%)
WINDOW/DOORS (GLASS) - 144 SF (32.14%)



02 GARAGE A ELEVATION WEST
1/8" = 1'-0"

BRICK 1 - "WILLIAMSBURG - STONE CITY" - 1,004 SF (69.15%)
WINDOW/DOORS (GLASS) - 448 SF (30.85%)



01 GARAGE B ELEVATION WEST
1/8" = 1'-0"

BRICK 1 - "WILLIAMSBURG - STONE CITY" - 456 SF (62.30%)
WINDOW/DOORS (GLASS) - 276 SF (37.70%)

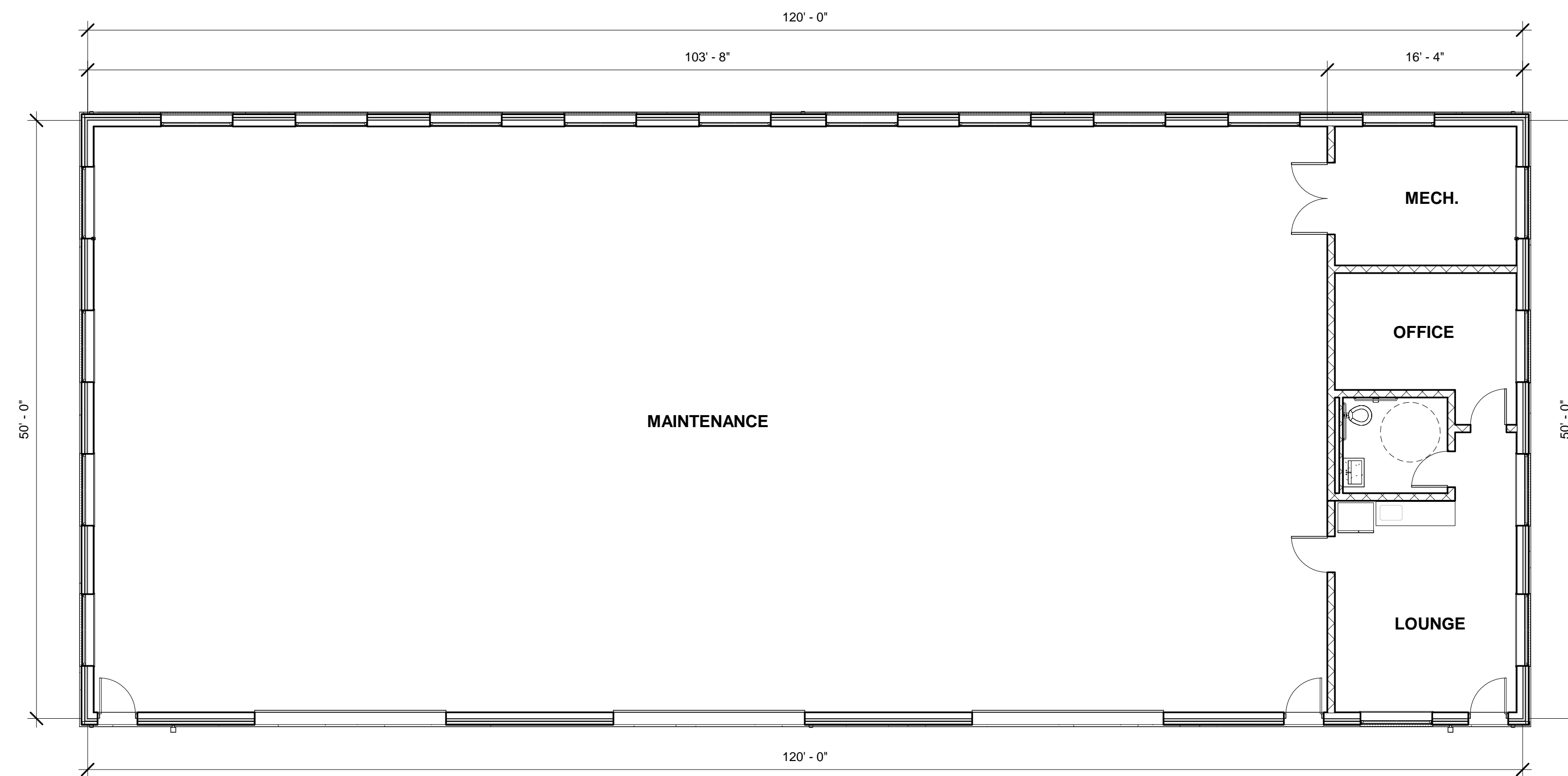

05 MAINTENANCE BUILDING FLOOR PLAN.
1/8" = 1'-0"



04 MAINTENANCE ELEVATION EAST
1/8" = 1'-0"

BRICK 1 - "WILLIAMSBURG - STONE CITY" - 1,134 SF (66.94%)
WINDOW/DOORS (GLASS) - 560 SF (33.06%)



03 MAINTENANCE ELEVATION NORTH
1/8" = 1'-0"

BRICK 1 - "WILLIAMSBURG - STONE CITY" - 497 SF (68.71%)
WINDOW/DOORS (GLASS) - 216 SF (30.29%)



02 MAINTENANCE ELEVATION SOUTH
1/8" = 1'-0"

BRICK 1 - "WILLIAMSBURG - STONE CITY" - 497 SF (68.71%)
WINDOW/DOORS (GLASS) - 216 SF (30.29%)



01 MAINTENANCE ELEVATION WEST
1/8" = 1'-0"

BRICK 1 - "WILLIAMSBURG - STONE CITY" - 984 SF (58.09%)
WINDOW/DOORS (GLASS) - 710 SF (41.91%)